

ESP32-WROOM-32SE

Datasheet



Version 1.2
Espressif Systems
Copyright © 2021

About This Document

This document provides the specifications for the ESP32-WROOM-32SE module.

Document Updates

Please always refer to the latest version on <https://www.espressif.com/en/support/download/documents>.

Revision History

For revision history of this document, please refer to the [last page](#).

Documentation Change Notification

Espressif provides email notifications to keep customers updated on changes to technical documentation.

Please subscribe at www.espressif.com/en/subscribe. Note that you need to update your subscription to receive notifications of new products you are not currently subscribed to.

Certification

Download certificates for Espressif products from www.espressif.com/en/certificates.

Contents

1	Overview	6
2	Pin Definitions	8
2.1	Pin Layout	8
2.2	Pin Description	8
2.3	Strapping Pins	10
3	Functional Description	12
3.1	CPU and Internal Memory	12
3.2	External Flash and SRAM	12
3.3	Crystal Oscillators	12
3.4	RTC and Low-Power Management	12
4	Peripherals and Sensors	14
5	Electrical Characteristics	15
5.1	Absolute Maximum Ratings	15
5.2	Recommended Operating Conditions	15
5.3	DC Characteristics (3.3 V, 25 °C)	15
5.4	Wi-Fi Radio	16
5.5	BLE Radio	17
	5.5.1 Receiver	17
	5.5.2 Transmitter	17
5.6	Reflow Profile	18
6	Schematics	19
7	Peripheral Schematics	20
8	Physical Dimensions	21
9	Recommended PCB Land Pattern	22
10	Learning Resources	23
10.1	Must-Read Documents	23
10.2	Must-Have Resources	23
	Revision History	25

List of Tables

1	ESP32-WROOM-32SE Specifications	6
2	Pin Definitions	8
3	Strapping Pins	10
4	Absolute Maximum Ratings	15
5	Recommended Operating Conditions	15
6	DC Characteristics (3.3 V, 25 °C)	15
7	Wi-Fi Radio Characteristics	16
8	Receiver Characteristics – BLE	17
9	Transmitter Characteristics – BLE	17

List of Figures

1	ESP32-WROOM-32SE Pin Layout (Top View)	8
2	Reflow Profile	18
3	ESP32-WROOM-32SE Schematics	19
4	ESP32-WROOM-32SE Peripheral Schematics	20
5	Physical Dimensions of ESP32-WROOM-32SE	21
6	Recommended PCB Land Pattern of ESP32-WROOM-32SE	22

1 Overview

ESP32-WROOM-32SE is a powerful, generic Wi-Fi+Bluetooth®+Bluetooth LE MCU module that targets a wide variety of applications, ranging from low-power sensor networks to the most demanding tasks, such as voice encoding, music streaming and MP3 decoding. ESP32-WROOM-32SE has a built-in ATECC608A chip, which acts as a secure storage for device certificates. For more information about the ATECC608A chip, please refer to its [datasheet](#).

At the core of the module is the ESP32-D0WD chip*. The chip embedded is designed to be scalable and adaptive. There are two CPU cores that can be individually controlled, and the CPU clock frequency is adjustable from 80 MHz to 240 MHz. The chip also has a low-power co-processor that can be used instead of the CPU to save power while performing tasks that do not require much computing power, such as monitoring of peripherals. ESP32 integrates a rich set of peripherals, ranging from capacitive touch sensors, Hall sensors, SD card interface, Ethernet, high-speed SPI, UART, I²S and I²C.

Note:

* For details on the part numbers of the ESP32 family of chips, please refer to the document [ESP32 Datasheet](#).

The integration of Bluetooth®, Bluetooth LE and Wi-Fi ensures that a wide range of applications can be targeted, and that the module is all-around: using Wi-Fi allows a large physical range and direct connection to the Internet through a Wi-Fi router, while using Bluetooth allows the user to conveniently connect to the phone or broadcast low energy beacons for its detection. The sleep current of the ESP32 chip is less than 5 μ A, making it suitable for battery powered and wearable electronics applications. The module supports a data rate of up to 150 Mbps, and 20 dBm output power at the antenna to ensure the widest physical range. As such the module does offer industry-leading specifications and the best performance for electronic integration, range, power consumption, and connectivity.

The operating system chosen for ESP32 is freeRTOS with LwIP; TLS 1.2 with hardware acceleration is built in as well. Secure (encrypted) over the air (OTA) upgrade is also supported, so that users can upgrade their products even after their release, at minimum cost and effort.

Table 1 provides the specifications of ESP32-WROOM-32SE.

Table 1: ESP32-WROOM-32SE Specifications

Categories	Items	Specifications
Certification	RF certification	FCC/CE-RED
	Green certification	RoHS/REACH
Test	Reliability	HTOL/HTSL/uHAST/TCT/ESD
Wi-Fi	Protocols	802.11 b/g/n (802.11n up to 150 Mbps)
		A-MPDU and A-MSDU aggregation and 0.4 μ s guard interval support
	Frequency range	2.4 ~ 2.5 GHz
Bluetooth	Radio	Bluetooth v4.2 BR/EDR and BLE specification
		NZIF receiver with -97 dBm sensitivity
		Class-1, class-2 and class-3 transmitter
		AFH

Categories	Items	Specifications
	Audio	CVSD and SBC
Hardware	Module interfaces	SD card, UART, SPI, SDIO, I ² C, LED PWM, Motor PWM, I ² S, IR, pulse counter, GPIO, capacitive touch sensor, ADC, DAC, Two-Wire Automotive Interface (TWAI [®] , compatible with ISO11898-1)
	On-chip sensor	Hall sensor
	Integrated crystal	40 MHz crystal
	Integrated SPI flash	4 MB
	Operating voltage/Power supply	3.0 V ~ 3.6 V
	Operating current	Average: 80 mA
	Minimum current delivered by power supply	500 mA
	Recommended operating temperature range	-40 °C ~ +85 °C
	Package size	(18.00±0.10) mm × (25.50±0.10) mm × (3.10±0.10) mm
	Moisture sensitivity level (MSL)	Level 3

2 Pin Definitions

2.1 Pin Layout

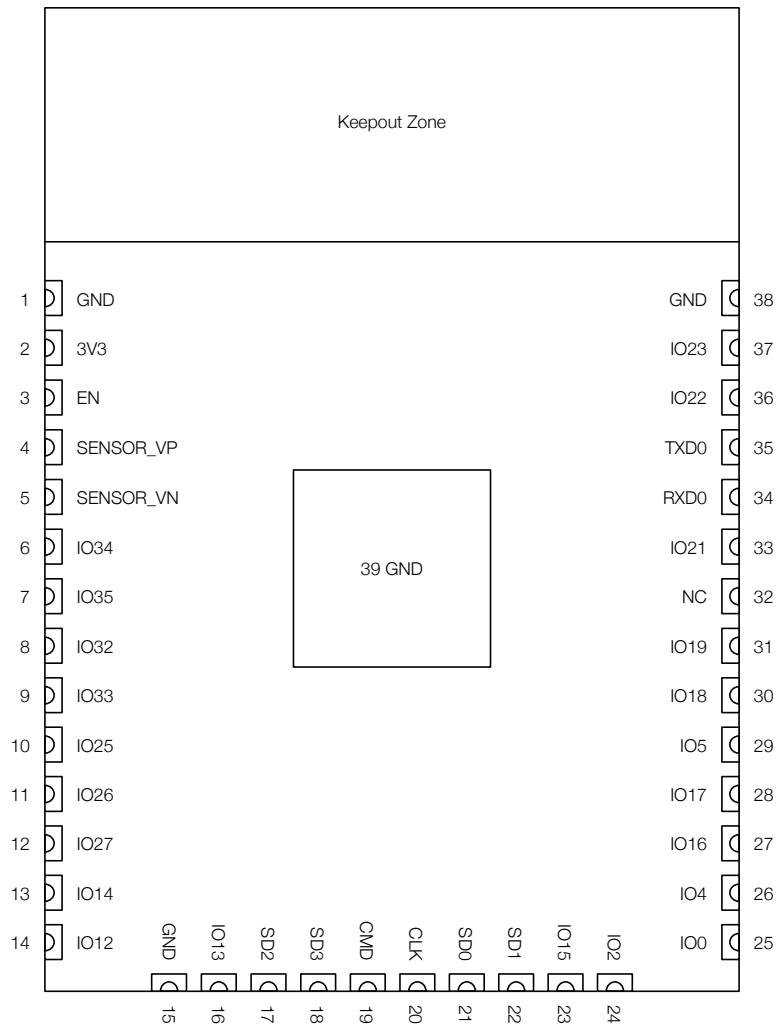

Figure 1: ESP32-WROOM-32SE Pin Layout (Top View)

2.2 Pin Description

ESP32-WROOM-32SE has 38 pins. See pin definitions in Table 2.

Table 2: Pin Definitions

Name	No.	Type	Function
GND	1	P	Ground
3V3	2	P	Power supply
EN	3	I	Module-enable signal. Active high.
SENSOR_VP	4	I	GPIO36, ADC1_CH0, RTC_GPIO0
SENSOR_VN	5	I	GPIO39, ADC1_CH3, RTC_GPIO3
IO34	6	I	GPIO34, ADC1_CH6, RTC_GPIO4

Name	No.	Type	Function
IO35	7	I	GPIO35, ADC1_CH7, RTC_GPIO5
IO32	8	I/O	GPIO32, XTAL_32K_P (32.768 kHz crystal oscillator input), ADC1_CH4, TOUCH9, RTC_GPIO9
IO33	9	I/O	GPIO33, XTAL_32K_N (32.768 kHz crystal oscillator output), ADC1_CH5, TOUCH8, RTC_GPIO8
IO25	10	I/O	GPIO25, DAC_1, ADC2_CH8, RTC_GPIO6, EMAC_RXD0
IO26	11	I/O	GPIO26, DAC_2, ADC2_CH9, RTC_GPIO7, EMAC_RXD1
IO27	12	I/O	GPIO27, ADC2_CH7, TOUCH7, RTC_GPIO17, EMAC_RX_DV
IO14	13	I/O	GPIO14, ADC2_CH6, TOUCH6, RTC_GPIO16, MTMS, HSPICLK, HS2_CLK, SD_CLK, EMAC_TXD2
IO12	14	I/O	GPIO12, ADC2_CH5, TOUCH5, RTC_GPIO15, MTDI, HSPIQ, HS2_DATA2, SD_DATA2, EMAC_TXD3
GND	15	P	Ground
IO13	16	I/O	GPIO13, ADC2_CH4, TOUCH4, RTC_GPIO14, MTCK, HSPID, HS2_DATA3, SD_DATA3, EMAC_RX_ER
SHD/SD2 ¹	17	I/O	GPIO9, SD_DATA2, SPIHD, HS1_DATA2, U1RXD
SWP/SD3 ¹	18	I/O	GPIO10, SD_DATA3, SPIWP, HS1_DATA3, U1TXD
SCS/CMD ¹	19	I/O	GPIO11, SD_CMD, SPICS0, HS1_CMD, U1RTS
SCK/CLK ¹	20	I/O	GPIO6, SD_CLK, SPICLK, HS1_CLK, U1CTS
SDO/SD0 ¹	21	I/O	GPIO7, SD_DATA0, SPIQ, HS1_DATA0, U2RTS
SDI/SD1 ¹	22	I/O	GPIO8, SD_DATA1, SPID, HS1_DATA1, U2CTS
IO15	23	I/O	GPIO15, ADC2_CH3, TOUCH3, MTDO, HSPICS0, RTC_GPIO13, HS2_CMD, SD_CMD, EMAC_RXD3
IO2	24	I/O	GPIO2, ADC2_CH2, TOUCH2, RTC_GPIO12, HSPIWP, HS2_DATA0, SD_DATA0
IO0	25	I/O	GPIO0, ADC2_CH1, TOUCH1, RTC_GPIO11, CLK_OUT1, EMAC_TX_CLK
IO4	26	I/O	GPIO4, ADC2_CH0, TOUCH0, RTC_GPIO10, HSPICLK, HS2_DATA1, SD_DATA1, EMAC_TX_ER
IO16 ²	27	I/O	I ² C_SDA
IO17 ²	28	I/O	I ² C_SCL
IO5	29	I/O	GPIO5, VSPICS0, HS1_DATA6, EMAC_RX_CLK
IO18	30	I/O	GPIO18, VSPICLK, HS1_DATA7
IO19	31	I/O	GPIO19, VSPIQ, U0CTS, EMAC_TXD0
NC	32	-	-
IO21	33	I/O	GPIO21, VSPIHD, EMAC_TX_EN
RXD0	34	I/O	GPIO3, U0RXD, CLK_OUT2
TXD0	35	I/O	GPIO1, U0TXD, CLK_OUT3, EMAC_RXD2
IO22	36	I/O	GPIO22, VSPIWP, U0RTS, EMAC_TXD1
IO23	37	I/O	GPIO23, VSPID, HS1_STROBE
GND	38	P	Ground

Notice:

1. Pins SCK/CLK, SDO/SD0, SDI/SD1, SHD/SD2, SWP/SD3 and SCS/CMD, namely, GPIO6 to GPIO11 are connected to the integrated SPI flash integrated on the module and are not recommended for other uses.
2. Pins IO16 and IO17 are connected to the ATECC608A chip. They are also brought out as module pins, but only allow I²C devices to be connected. Note that since IO16 and IO17 have internal pull-up resistors, the I²C devices should work with the matching pull-ups and no additional pull-ups outside the module are required.

2.3 Strapping Pins

ESP32 has five strapping pins, which can be seen in Chapter 6 Schematics:

- MTDI
- GPIO0
- GPIO2
- MTDO
- GPIO5

Software can read the values of these five bits from register "GPIO_STRAPPING".

During the chip's system reset release (power-on-reset, RTC watchdog reset and brownout reset), the latches of the strapping pins sample the voltage level as strapping bits of "0" or "1", and hold these bits until the chip is powered down or shut down. The strapping bits configure the device's boot mode, the operating voltage of VDD_SDIO and other initial system settings.

Each strapping pin is connected to its internal pull-up/pull-down during the chip reset. Consequently, if a strapping pin is unconnected or the connected external circuit is high-impedance, the internal weak pull-up/pull-down will determine the default input level of the strapping pins.

To change the strapping bit values, users can apply the external pull-down/pull-up resistances, or use the host MCU's GPIOs to control the voltage level of these pins when powering on ESP32.

After reset release, the strapping pins work as normal-function pins.

Refer to Table 3 for a detailed boot-mode configuration by strapping pins.

Table 3: Strapping Pins

Voltage of Internal LDO (VDD_SDIO)			
Pin	Default	3.3 V	1.8 V
MTDI	Pull-down	0	1
Bootling Mode			
Pin	Default	SPI Boot	Download Boot
GPIO0	Pull-up	1	0
GPIO2	Pull-down	Don't-care	0
Enabling/Disabling Debugging Log Print over U0TXD During Bootling			
Pin	Default	U0TXD Active	U0TXD Silent
MTDO	Pull-up	1	0
Timing of SDIO Slave			

Pin	Default	FE Sampling FE Output	FE Sampling RE Output	RE Sampling FE Output	RE Sampling RE Output
MTDO	Pull-up	0	0	1	1
GPIO5	Pull-up	0	1	0	1

Note:

- Firmware can configure register bits to change the settings of "Voltage of Internal LDO (VDD_SDIO)" and "Timing of SDIO Slave" after booting.
- ESP32-WROOM-32SE integrates a 3.3 V SPI flash, so the pin MTDI cannot be set to 1 when the module is powered up.

3 Functional Description

This chapter describes the modules and functions integrated in ESP32-WROOM-32SE.

3.1 CPU and Internal Memory

ESP32-D0WD contains a dual-core Xtensa® 32-bit LX6 MCU. The internal memory includes:

- 448 KB of ROM for booting and core functions.
- 520 KB of on-chip SRAM for data and instructions.
- 8 KB of SRAM in RTC, which is called RTC FAST Memory and can be used for data storage; it is accessed by the main CPU during RTC Boot from the Deep-sleep mode.
- 8 KB of SRAM in RTC, which is called RTC SLOW Memory and can be accessed by the co-processor during the Deep-sleep mode.
- 1 Kbit of eFuse: 256 bits are used for the system (MAC address and chip configuration) and the remaining 768 bits are reserved for customer applications, including flash-encryption and chip-ID.

3.2 External Flash and SRAM

ESP32 supports multiple external QSPI flash and SRAM chips. More details can be found in Chapter SPI in the [ESP32 Technical Reference Manual](#). ESP32 also supports hardware encryption/decryption based on AES to protect developers' programs and data in flash.

ESP32 can access the external QSPI flash and SRAM through high-speed caches.

- The external flash can be mapped into CPU instruction memory space and read-only memory space simultaneously.
 - When external flash is mapped into CPU instruction memory space, up to 11 MB + 248 KB can be mapped at a time. Note that if more than 3 MB + 248 KB are mapped, cache performance will be reduced due to speculative reads by the CPU.
 - When external flash is mapped into read-only data memory space, up to 4 MB can be mapped at a time. 8-bit, 16-bit and 32-bit reads are supported.
- External SRAM can be mapped into CPU data memory space. Up to 4 MB can be mapped at a time. 8-bit, 16-bit and 32-bit reads and writes are supported.

ESP32-WROOM-32SE integrates a 4 MB of external SPI flash. The integrated SPI flash is connected to GPIO6, GPIO7, GPIO8, GPIO9, GPIO10 and GPIO11. These six pins cannot be used as regular GPIOs.

3.3 Crystal Oscillators

The module uses a 40-MHz crystal oscillator.

3.4 RTC and Low-Power Management

With the use of advanced power-management technologies, ESP32 can switch between different power modes.

For details on ESP32's power consumption in different power modes, please refer to section "RTC and Low-Power Management" in [ESP32 Datasheet](#).

4 Peripherals and Sensors

Please refer to Section Peripherals and Sensors in [ESP32 Datasheet](#).

Note:

- External connections can be made to any GPIO except for GPIOs in the range 6-11. These six GPIOs are connected to the module's integrated SPI flash.
- Pins IO16 and IO17 on the module are connected to the ATECC608A chip. They are also brought out as module pins, but only allow I²C devices to be connected.
- For details, please see Section 6 Schematics.

5 Electrical Characteristics

5.1 Absolute Maximum Ratings

Stresses beyond the absolute maximum ratings listed in Table 4 below may cause permanent damage to the device. These are stress ratings only, and do not refer to the functional operation of the device that should follow the [recommended operating conditions](#).

Table 4: Absolute Maximum Ratings

Symbol	Parameter	Min	Max	Unit
VDD33	Power supply voltage	-0.3	3.6	V
I_{output}^1	Cumulative IO output current	-	1,100	mA
T_{store}	Storage temperature	-40	150	°C

1. The module worked properly after a 24-hour test in ambient temperature at 25 °C, and the IOs in three domains (VDD3P3_RTC, VDD3P3_CPU, VDD_SDIO) output high logic level to ground. Please note that pins occupied by flash and/or PSRAM in the VDD_SDIO power domain were excluded from the test.
2. Please see Appendix IO_MUX of [ESP32 Datasheet](#) for IO's power domain.

5.2 Recommended Operating Conditions

Table 5: Recommended Operating Conditions

Symbol	Parameter	Min	Typical	Max	Unit
VDD33	Power supply voltage	3.0	3.3	3.6	V
I_{VDD}	Current delivered by external power supply	0.5	-	-	A
T	Operating temperature	-40	-	85	°C

5.3 DC Characteristics (3.3 V, 25 °C)

Table 6: DC Characteristics (3.3 V, 25 °C)

Symbol	Parameter	Min	Typ	Max	Unit	
C_{IN}	Pin capacitance	-	2	-	pF	
V_{IH}	High-level input voltage	$0.75 \times VDD^1$	-	$VDD^1 + 0.3$	V	
V_{IL}	Low-level input voltage	-0.3	-	$0.25 \times VDD^1$	V	
I_{IH}	High-level input current	-	-	50	nA	
I_{IL}	Low-level input current	-	-	50	nA	
V_{OH}	High-level output voltage	$0.8 \times VDD^1$	-	-	V	
V_{OL}	Low-level output voltage	-	-	$0.1 \times VDD^1$	V	
I_{OH}	High-level source current ($VDD^1 = 3.3$ V, $V_{OH} \geq 2.64$ V, output drive strength set to the maximum)	VDD3P3_CPU power domain ^{1, 2}	-	40	-	mA
		VDD3P3_RTC power domain ^{1, 2}	-	40	-	mA
		VDD_SDIO power domain ^{1, 3}	-	20	-	mA

Symbol	Parameter	Min	Typ	Max	Unit
I_{OL}	Low-level sink current ($V_{DD}^1 = 3.3\text{ V}$, $V_{OL} = 0.495\text{ V}$, output drive strength set to the maximum)	-	28	-	mA
R_{PU}	Resistance of internal pull-up resistor	-	45	-	$k\Omega$
R_{PD}	Resistance of internal pull-down resistor	-	45	-	$k\Omega$
V_{IL_nRST}	Low-level input voltage of CHIP_PU to power off the chip	-	-	0.6	V

Notes:

1. Please see Appendix IO_MUX of [ESP32 Datasheet](#) for IO's power domain. VDD is the I/O voltage for a particular power domain of pins.
2. For VDD3P3_CPU and VDD3P3_RTC power domain, per-pin current sourced in the same domain is gradually reduced from around 40 mA to around 29 mA, $V_{OH} \geq 2.64\text{ V}$, as the number of current-source pins increases.
3. Pins occupied by flash and/or PSRAM in the VDD_SDIO power domain were excluded from the test.

5.4 Wi-Fi Radio

Table 7: Wi-Fi Radio Characteristics

Parameter	Condition	Min	Typical	Max	Unit
Operating frequency range <i>note1</i>	-	2412	-	2484	MHz
Output impedance <i>note2</i>	-	-	See note 2	-	Ω
TX power <i>note3</i>	11n, MCS7	12	13	14	dBm
	11b mode	18.5	19.5	20.5	dBm
Sensitivity	11b, 1 Mbps	-	-97	-	dBm
	11b, 11 Mbps	-	-87	-	dBm
	11g, 6 Mbps	-	-92	-	dBm
	11g, 54 Mbps	-	-74	-	dBm
	11n, HT20, MCS0	-	-91	-	dBm
	11n, HT20, MCS7	-	-71	-	dBm
	11n, HT40, MCS0	-	-89	-	dBm
	11n, HT40, MCS7	-	-69	-	dBm
Adjacent channel rejection	11g, 6 Mbps	-	31	-	dB
	11g, 54 Mbps	-	14	-	dB
	11n, HT20, MCS0	-	31	-	dB
	11n, HT20, MCS7	-	13	-	dB

1. Device should operate in the frequency range allocated by regional regulatory authorities. Target operating frequency range is configurable by software.
2. For the modules that use IPEX antennas, the output impedance is 50 Ω . For other modules without IPEX antennas, users do not need to concern about the output impedance.
3. Target TX power is configurable based on device or certification requirements.

5.5 BLE Radio

5.5.1 Receiver

Table 8: Receiver Characteristics – BLE

Parameter	Conditions	Min	Typ	Max	Unit
Sensitivity @30.8% PER	-	-	-97	-	dBm
Maximum received signal @30.8% PER	-	0	-	-	dBm
Co-channel C/I	-	-	+10	-	dB
Adjacent channel selectivity C/I	F = F0 + 1 MHz	-	-5	-	dB
	F = F0 - 1 MHz	-	-5	-	dB
	F = F0 + 2 MHz	-	-25	-	dB
	F = F0 - 2 MHz	-	-35	-	dB
	F = F0 + 3 MHz	-	-25	-	dB
	F = F0 - 3 MHz	-	-45	-	dB
Out-of-band blocking performance	30 MHz ~ 2000 MHz	-10	-	-	dBm
	2000 MHz ~ 2400 MHz	-27	-	-	dBm
	2500 MHz ~ 3000 MHz	-27	-	-	dBm
	3000 MHz ~ 12.5 GHz	-10	-	-	dBm
Intermodulation	-	-36	-	-	dBm

5.5.2 Transmitter

Table 9: Transmitter Characteristics – BLE

Parameter	Conditions	Min	Typ	Max	Unit
RF transmit power	-	-	0	-	dBm
Gain control step	-	-	3	-	dBm
RF power control range	-	-12	-	+9	dBm
Adjacent channel transmit power	F = F0 ± 2 MHz	-	-52	-	dBm
	F = F0 ± 3 MHz	-	-58	-	dBm
	F = F0 ± > 3 MHz	-	-60	-	dBm
Δf_{1avg}	-	-	-	265	kHz
Δf_{2max}	-	247	-	-	kHz
$\Delta f_{2avg}/\Delta f_{1avg}$	-	-	-0.92	-	-
ICFT	-	-	-10	-	kHz
Drift rate	-	-	0.7	-	kHz/50 μ s
Drift	-	-	2	-	kHz

5.6 Reflow Profile

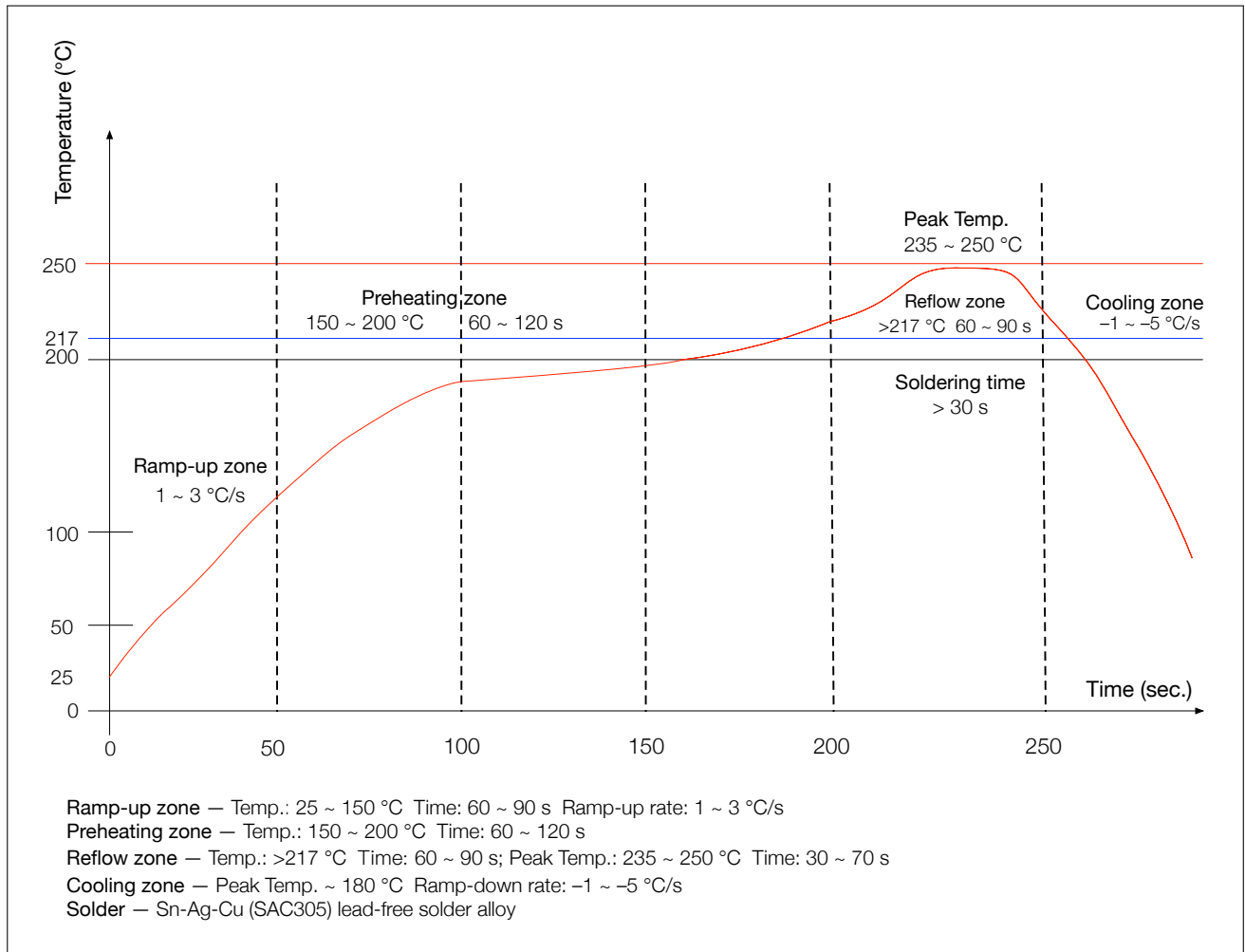

Figure 2: Reflow Profile

Note:

Solder the module in a single reflow.

6 Schematics

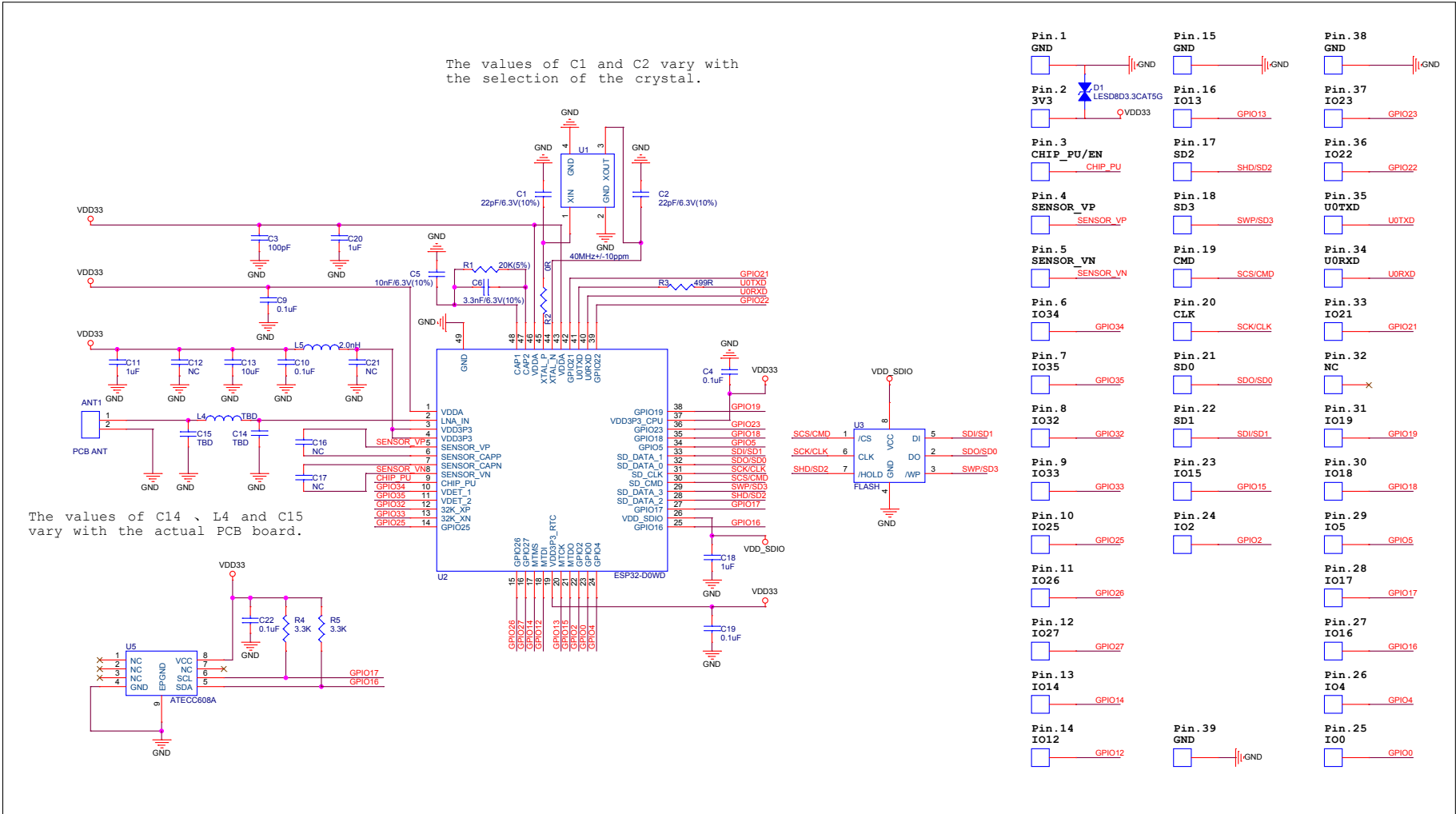

Figure 3: ESP32-WROOM-32SE Schematics

7 Peripheral Schematics

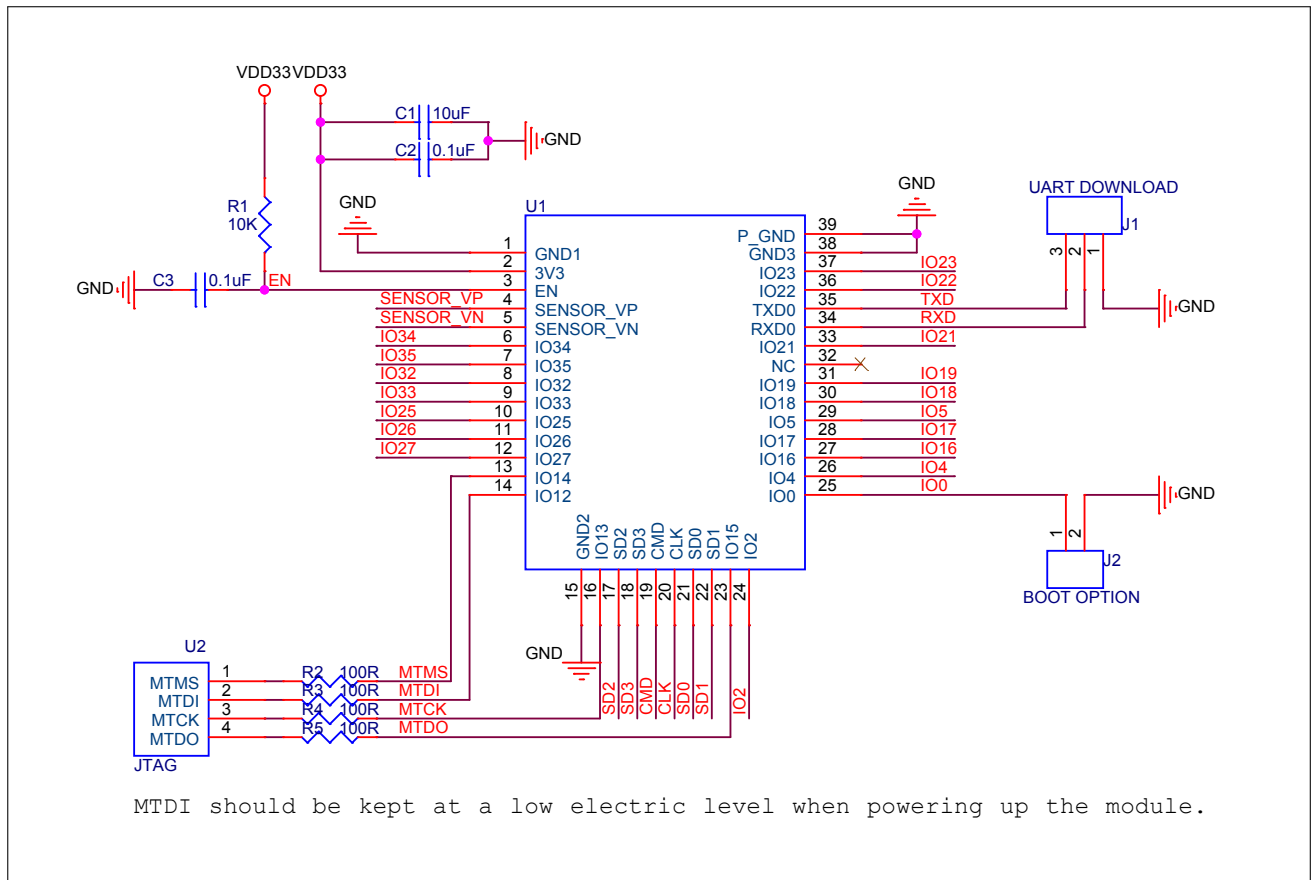

Figure 4: ESP32-WROOM-32SE Peripheral Schematics

Note:

- Soldering Pad 39 to the Ground of the base board is not necessary for a satisfactory thermal performance. If users do want to solder it, they need to ensure that the correct quantity of soldering paste is applied.
- To ensure the power supply to the ESP32 chip during power-up, it is advised to add an RC delay circuit at the EN pin. The recommended setting for the RC delay circuit is usually $R = 10\text{ k}\Omega$ and $C = 1\ \mu\text{F}$. However, specific parameters should be adjusted based on the power-up timing of the module and the power-up and reset sequence timing of the chip. For ESP32's power-up and reset sequence timing diagram, please refer to Section *Power Scheme* in [ESP32 Datasheet](#).

8 Physical Dimensions

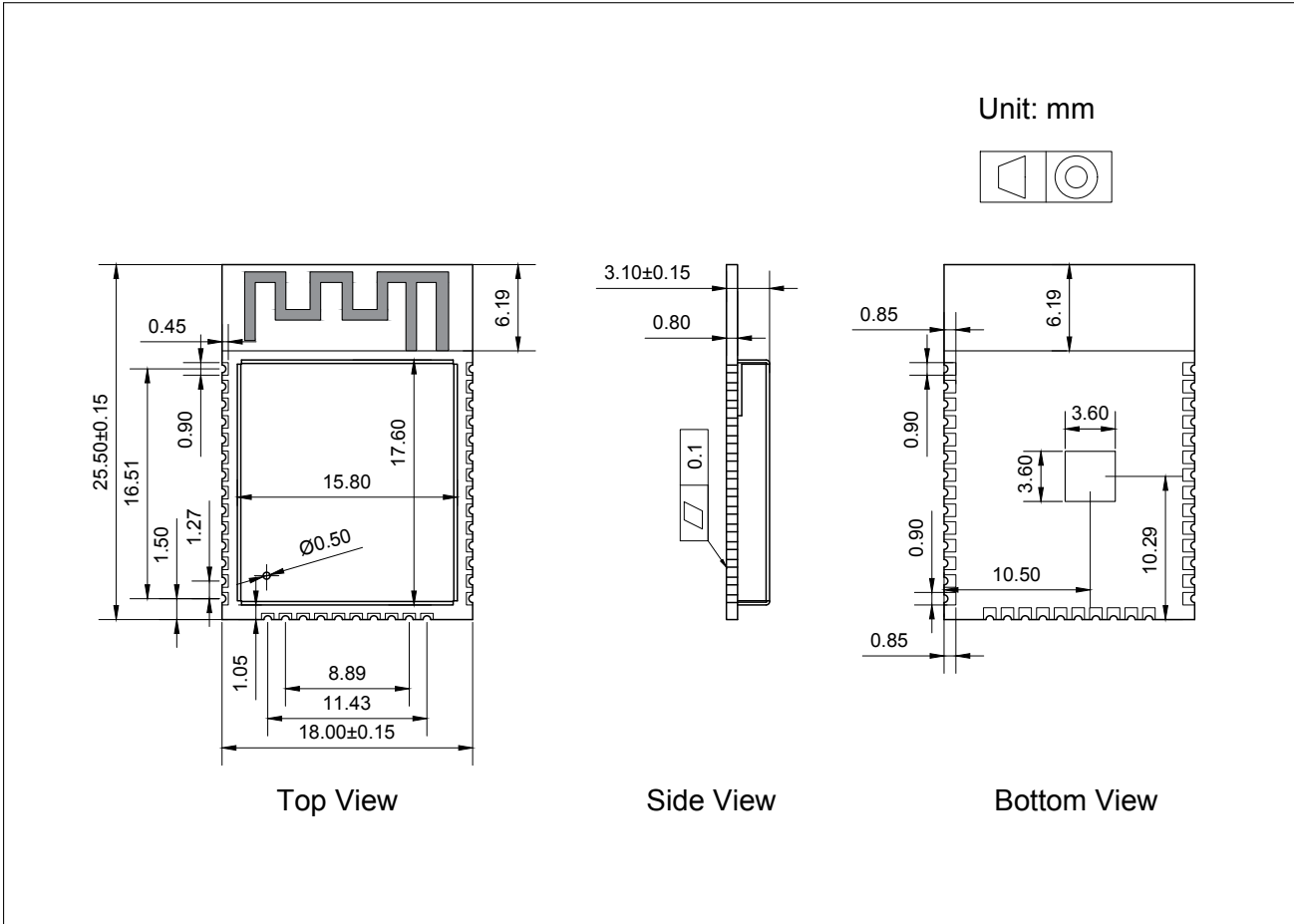

Figure 5: Physical Dimensions of ESP32-WROOM-32SE

9 Recommended PCB Land Pattern

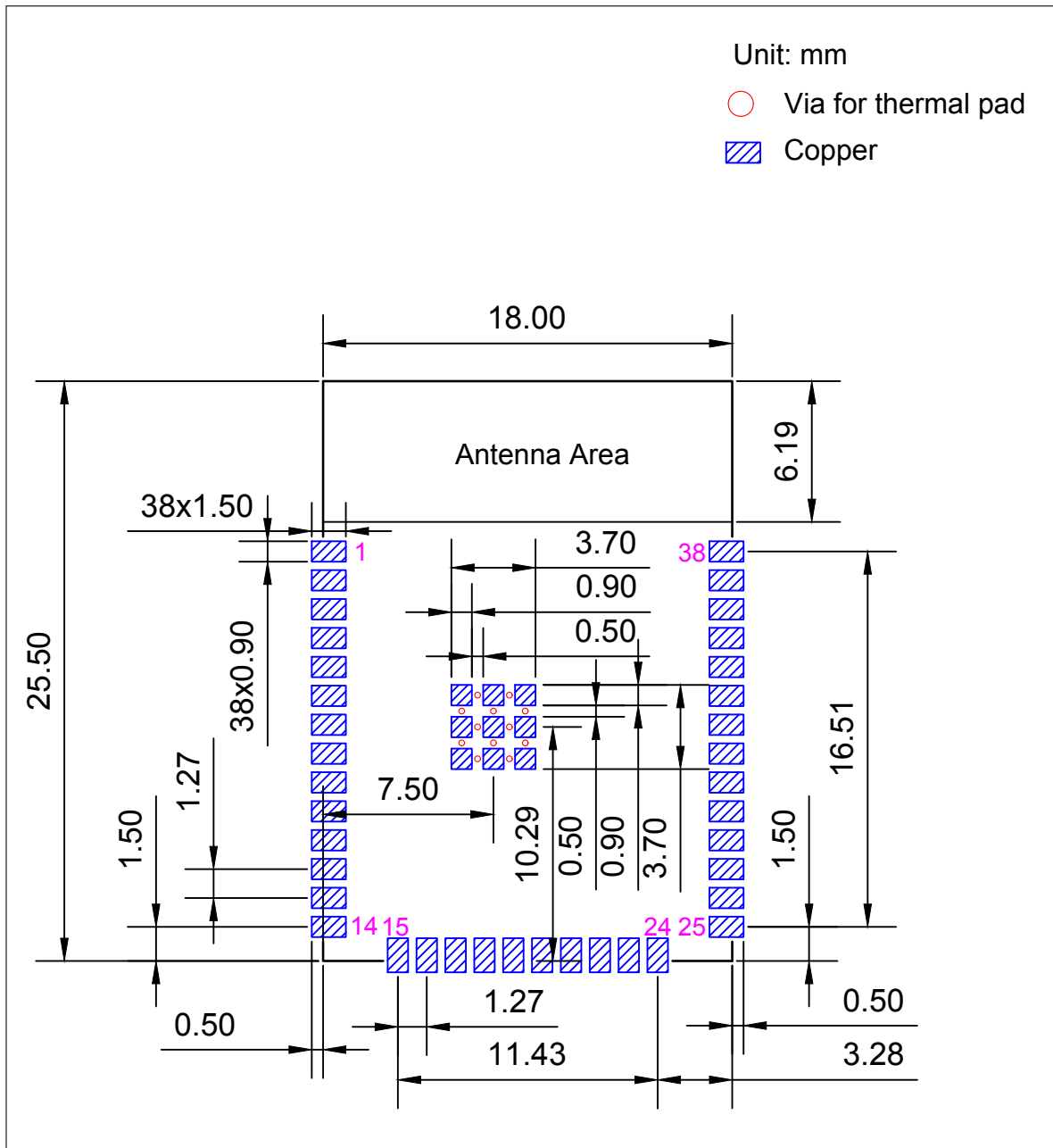

Figure 6: Recommended PCB Land Pattern of ESP32-WROOM-32SE

10 Learning Resources

10.1 Must-Read Documents

The following link provides documents related to ESP32.

- [ESP32 Datasheet](#)
This document provides an introduction to the specifications of the ESP32 hardware, including overview, pin definitions, functional description, peripheral interface, electrical characteristics, etc.
- [ESP32 ECO V3 User Guide](#)
This document describes differences between V3 and previous ESP32 silicon wafer revisions.
- [ECO and Workarounds for Bugs in ESP32](#)
This document details hardware errata and workarounds in the ESP32.
- [ESP-IDF Programming Guide](#)
It hosts extensive documentation for ESP-IDF ranging from hardware guides to API reference.
- [ESP32 Technical Reference Manual](#)
The manual provides detailed information on how to use the ESP32 memory and peripherals.
- [ESP32 Hardware Resources](#)
The zip files include the schematics, PCB layout, Gerber and BOM list of ESP32 modules and development boards.
- [ESP32 Hardware Design Guidelines](#)
The guidelines outline recommended design practices when developing standalone or add-on systems based on the ESP32 series of products, including the ESP32 chip, the ESP32 modules and development boards.
- [ESP32 AT Instruction Set and Examples](#)
This document introduces the ESP32 AT commands, explains how to use them, and provides examples of several common AT commands.
- [Espressif Products Ordering Information](#)

10.2 Must-Have Resources

Here are the ESP32-related must-have resources.

- [ESP32 BBS](#)
This is an Engineer-to-Engineer (E2E) Community for ESP32 where you can post questions, share knowledge, explore ideas, and help solve problems with fellow engineers.
- [ESP32 GitHub](#)
ESP32 development projects are freely distributed under Espressif's MIT license on GitHub. It is established to help developers get started with ESP32 and foster innovation and the growth of general knowledge about the hardware and software surrounding ESP32 devices.
- [ESP32 Tools](#)
This is a webpage where users can download ESP32 Flash Download Tools and the zip file "ESP32 Certification and Test".

- [ESP-IDF](#)

This webpage links users to the official IoT development framework for ESP32.

- [ESP32 Resources](#)

This webpage provides the links to all available ESP32 documents, SDK and tools.

Revision History

Date	Version	Release notes
2021.02	V1.2	Updated Figure 5: <i>Physical Dimensions of ESP32-WROOM-32SE</i> and Figure 6: <i>Recommended PCB Land Pattern of ESP32-WROOM-32SE</i> . Modified the note below Figure 2: <i>Reflow Profile</i> . Updated the trade mark from TWAI™ to TWAI®.
2020.11	V1.1	Added TWAI™ in Table 1; Updated the C value in RC circuit from 0.1 μF to 1 μF .
2019.12	V1.0	First release.



www.espressif.com

Disclaimer and Copyright Notice

Information in this document, including URL references, is subject to change without notice.

ALL THIRD PARTY'S INFORMATION IN THIS DOCUMENT IS PROVIDED AS IS WITH NO WARRANTIES TO ITS AUTHENTICITY AND ACCURACY.

NO WARRANTY IS PROVIDED TO THIS DOCUMENT FOR ITS MERCHANTABILITY, NON-INFRINGEMENT, FITNESS FOR ANY PARTICULAR PURPOSE, NOR DOES ANY WARRANTY OTHERWISE ARISING OUT OF ANY PROPOSAL, SPECIFICATION OR SAMPLE.

All liability, including liability for infringement of any proprietary rights, relating to use of information in this document is disclaimed. No licenses express or implied, by estoppel or otherwise, to any intellectual property rights are granted herein.

The Wi-Fi Alliance Member logo is a trademark of the Wi-Fi Alliance. The Bluetooth logo is a registered trademark of Bluetooth SIG.

All trade names, trademarks and registered trademarks mentioned in this document are property of their respective owners, and are hereby acknowledged.

Copyright © 2021 Espressif Systems (Shanghai) Co., Ltd. All rights reserved.