

# ALTRONICS Specification Sheet

Phone: 1300 797 007 Internet: [www.altronics.com.au](http://www.altronics.com.au)  
 Fax: 1300 789 777 Email: [info@altronics.com.au](mailto:info@altronics.com.au)  
 International Phone: +61 8 9428 2188

Manufactures please note, we recommend that a sample is obtained to confirm suitability. Specifications subject to change without notice.E&OE. © Altronic Distributors Pty. Ltd. ABN 84 177 396 871

Revision Date: 16/03//2010

Altronics Part Number	Description	Supplier Ordering Info
H 0370	Mounting Feet Set 4 Suit H 0312A / H 0332A	MF 0055 ROHS

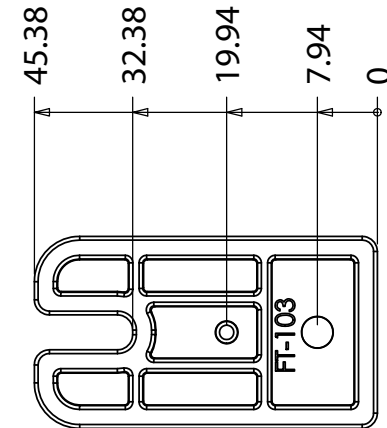
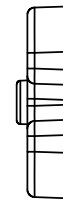
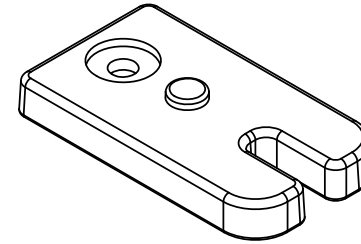
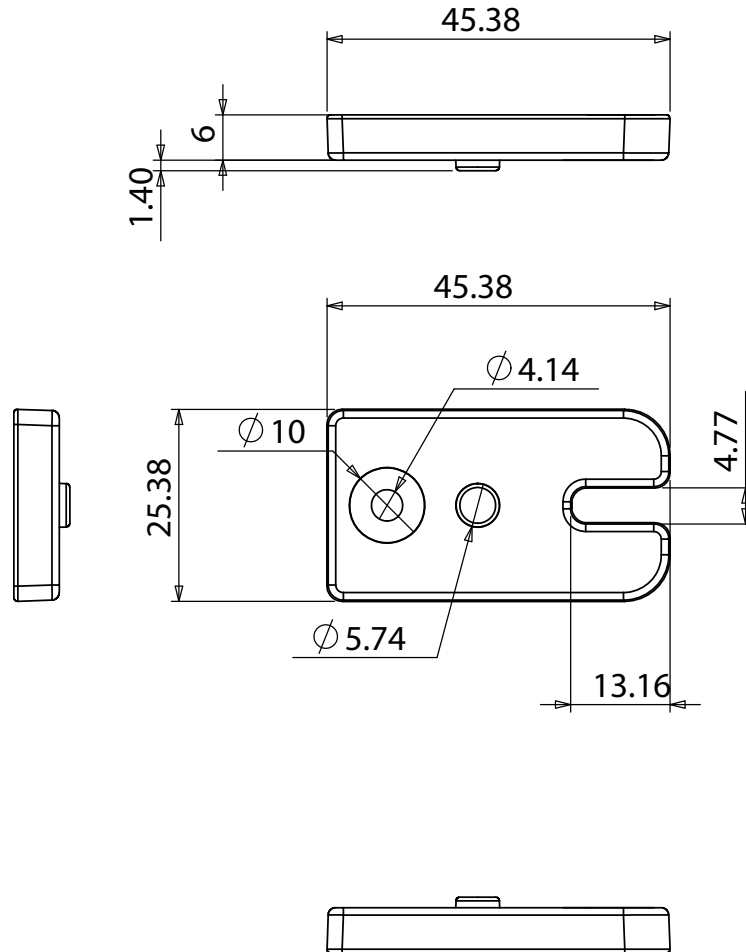

Material: ABSUL94-HB, light grey.

1 PACK COMPRISES OF  
 Mounting feet x 4 pcs  
 Fixing screws x 4 pcs  
 Wall anchor mounting screws x 4 pcs  
 Plastic wall anchor x 4 pcs

Measurements given in mm.